

FS 94

STIHL



2 - 38 Instruction Manual



Contents

1	Guide to Using this Manual.....	2
2	Safety Precautions and Working Techniques.....	2
3	Approved Combinations of Cutting Attachment, Deflector, Handle and Harness.....	11
4	Approved Power Tool Attachments.....	12
5	Mounting the Bike Handle.....	12
6	Mounting the Loop Handle.....	13
7	Fitting the Carrying Ring.....	16
8	Mounting the deflector.....	16
9	Mounting the Cutting Attachment.....	17
10	Fuel.....	20
11	Fueling.....	21
12	Fitting the Harness.....	22
13	Balancing the Machine.....	23
14	Starting / Stopping the Engine.....	24
15	Transporting the Unit.....	26
16	Operating Instructions.....	28
17	Cleaning the Air Filter.....	28
18	Adjusting the Carburetor.....	28
19	Spark Plug.....	29
20	Lubricating the Gearbox.....	30
21	Storing the Machine.....	30
22	Sharpening Metal Cutting Blades.....	30
23	Maintaining the Mowing Head.....	31
24	Inspection and Maintenance by User.....	31
25	Inspections and Maintenance by Dealer...	32
26	Maintenance and Care.....	33
27	Minimize Wear and Avoid Damage.....	34
28	Main Parts.....	35
29	Specifications.....	35
30	Maintenance and Repairs.....	36
31	Disposal.....	37
32	EC Declaration of Conformity.....	37
33	UKCA Declaration of Conformity.....	37

1 Guide to Using this Manual

1.1 Pictograms

The meanings of the pictograms attached to the machine are explained in this manual.

Depending on the model concerned, the following pictograms may be attached to your machine.



Fuel tank; fuel mixture of gasoline and engine oil



Operate decompression valve



Manual fuel pump



Operate manual fuel pump



Tube of grease



Intake air: Summer operation



Intake air: Winter operation



Handle heating

1.2 Symbols in text



WARNING

Warning where there is a risk of an accident or personal injury or serious damage to property.

NOTICE

Caution where there is a risk of damaging the machine or its individual components.

1.3 Engineering improvements

STIHL's philosophy is to continually improve all of its products. For this reason we may modify the design, engineering and appearance of our products periodically.

Therefore, some changes, modifications and improvements may not be covered in this manual.

2 Safety Precautions and Working Techniques



Because the machine is a high-speed fast-cutting power tool, special safety precautions must be observed to reduce the risk of personal injury.



It is important you read and understand the User Manual before commissioning and keep it in a safe place for future reference. Non-compliance with the User Manual may cause serious or even fatal injury.

Observe all applicable local safety regulations, e.g. by trade organizations, social insurance institutions, labor safety authorities etc.

If you have never used a power tool before: Have your dealer or other experienced user show you how to operate your machine – or

attend a special course to learn how to operate it.

Minors should never be allowed to use the machine – except for apprentices over the age of 16 when working under supervision.

Children, animals and bystanders must remain at a distance.

When not using the machine, it must be laid down in such a way that it does not endanger anyone. Ensure that the machine cannot be used without authorization.

The user is responsible for accidents or risks involving third parties or their property.

Do not lend or rent your power tool without the User Manual. Be sure that anyone using it understands the information contained in this manual.

The use of machines that emit noise may be limited to certain hours of the day as specified by national and/or regional or local regulations.

Anyone operating the machine must be well rested, in good physical health and in good mental condition.

If you have any condition that might be aggravated by strenuous work, check with your doctor before operating a machine.

If you have a pacemaker: The ignition system of your machine produces an electromagnetic field of very low intensity. This field may interfere with some pacemakers. STIHL recommends that persons with pacemakers consult their physician and the pacemaker manufacturer to reduce any health risk.

Anyone who has consumed alcohol or drugs or medicines affecting their ability to react must not operate a power tool.

Depending on the cutting attachment fitted, use your power tool only for cutting grass, wild growth, shrubs, scrub, bushes, small diameter trees and similar materials.

The machine must not be used for any other purposes – **risk of accidents!**

Only use cutting attachments and accessories that are explicitly approved for this power tool model by STIHL or are technically identical. If you have any questions in this respect, consult your dealer. Use only high quality parts and accessories. In order to avoid the risk of accidents and damage to the machine.

STIHL recommends the use of original STIHL tools and accessories. They are specifically designed to match the product and meet your performance requirements.

Never attempt to modify your power tool in any way since this may increase the risk of personal injury. STIHL excludes all liability for personal injury and damage to property caused while using unauthorised attachments.

The guard provided with your machine may not protect the operator from all foreign objects (gravel, glass, wire etc.) ejected by the revolving cutting attachment. Ejected objects may also ricochet and strike the operator.

Do not use a high-pressure washer to clean the power tool. The solid jet of water may damage parts of the unit.

2.1 Clothing and equipment

Wear proper protective clothing and equipment.



Clothing must be sturdy but allow complete freedom of movement. Wear close-fitting clothes such as a boiler suit, not a loose jacket.

Do not wear clothing which could become trapped in wood, brush or moving parts of the machine. Do not wear a scarf, necktie or jewelry. Tie up and confine long hair above your shoulders.



Wear safety boots with steel toe caps and non-slip soles.

Sturdy shoes with non-slip shoes are permissible only when using mowing heads.



WARNING



To reduce the risk of eye injuries, wear close-fitting safety glasses in accordance with European Standard EN 166. Make sure the safety glasses are a snug fit.

Wear face protection and make sure it is a good fit. Face protection alone is not sufficient to protect the eyes.

Wear "personal" sound protection, e.g. ear defenders.

Wear a safety hard hat for thinning operations, when working in high scrub and where there is a danger of head injuries from falling objects.



Wear sturdy protective gloves made of a resistant material (e.g. leather).

STIHL can supply a comprehensive range of personal protective equipment.

2.2 Transporting the machine

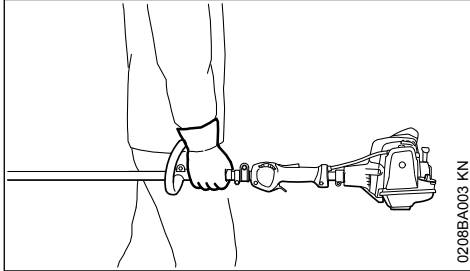

0208BA003 KN

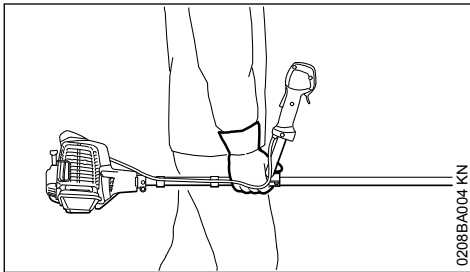

0208BA004 KN

Always stop the engine.

The tool should be carried hanging on the harness or by the shaft, in such a way that it is balanced.

To reduce the risk of cut injuries, fit transport guard on the cutting attachment, even when carrying the tool for short distances – see also "Transporting the Unit".



Avoid touching hot parts of the machine and gearbox – **risk of burns!**

By vehicle: When transporting in a vehicle, properly secure your machine to prevent turnover, damage and fuel spillage.

2.3 Refueling



Gasoline is highly flammable – keep away from fire or flame – do not spill any fuel – no smoking.

Always shut off the engine before refueling.

Do not fuel a hot engine – **fuel may spill and cause a fire.**

Open the fuel cap carefully to allow any pressure build-up in the tank to release slowly and avoid fuel spillage.

Only refuel the machine in a well ventilated place. If fuel has been spilled, immediately clean the machine – do not allow your clothes to be splashed with fuel. If that happens, change your clothes at once.



After refueling, close the fuel cap as tightly as possible.

This helps reduce the risk of engine vibrations causing an incorrectly tightened fuel cap to loosen or come off and spill fuel.

Check for leaks. Do not start the engine if there is a fuel leak – **serious or fatal burns could result!**

2.4 Before starting

Check that your power tool is properly assembled and in good condition – refer to appropriate chapters in the User Manual.

- Check the fuel system for leaks, especially the visible parts, e. g., fuel cap, hose connections, manual fuel pump (only in machines with a manual fuel pump). In case of leakage and damage, do not start the engine – **risk of fire!** Have the machine serviced by a dealer before using it
- Use only an approved combination of cutting attachment, deflector, handle and harness. All parts must be assembled properly and securely
- The stop switch / slide control must be easy to actuate
- Check the rotary knob for warm start, throttle trigger lockout, throttle trigger and set wheel for smooth action – the throttle trigger must return automatically to idle position. From the warm start knob position **II**, it must return to the run position **I** when the throttle trigger lockout and throttle trigger are pressed simultaneously
- Check that the spark plug boot is secure – a loose boot may cause sparking that could ignite combustible fumes **and cause a fire!**
- Cutting attachment or interchangeable attachment: correctly fitted, secure and in perfect condition
- Safety devices (e. g., deflector for cutting attachments, rider plate) for damage and/or

wear. Always replace damaged parts. Do not use the machine with a damaged deflector or worn rider plate (if the writing and arrows are no longer discernible)

- Never attempt to modify the controls or safety devices
- Keep the handles dry and clean – free from oil and dirt – this is important for safe control of the machine
- Adjust the harness and handle(s) to suit your height and reach Note the information in the chapters "Fitting the Harness" and "Balancing the Machine".

To reduce the risk of personal injury, do not operate your power tool if it is damaged or not properly assembled!

To prepare for emergencies when using a harness: Practice setting down the machine quickly. To avoid damage, do not throw the machine to the ground when practicing.

2.5 Starting the engine

Start the engine at least 3 meters from the fueling spot, outdoors only.

Place the unit on firm ground in an open area. Make sure you have good balance and secure footing. Hold the unit securely. The cutting attachment must be clear of the ground and all other obstructions because it may begin to run when the engine starts.

This is a one-person machine – ensure that there is no-one within 15 meters of the machine, not even when starting the power tool! **Risk of injury** due to ejected objects!



Avoid contact with the cutting attachment – **risk of injury!**



Do not drop-start the power tool – start the engine as described in the User Manual. The cutting attachment runs on for a short while after releasing the throttle trigger – **coasting effect!**

Check engine idling: The cutting attachment must remain at a standstill when the engine idles – throttle trigger released.

Keep easily combustible materials (e. g., wood chips, bark, dry grass, fuel) away from hot exhaust gases and hot muffler surfaces – **risk of fire!**

2.6 Holding and guiding the machine

Always hold the unit firmly with both hands on the handles.

Make sure you always have good balance and secure footing.

2.6.1 For versions with bike handle

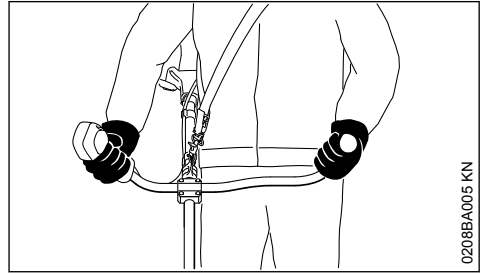

Right hand on control handle, left hand on grip on handlebar.

2.6.2 For versions with loop handle

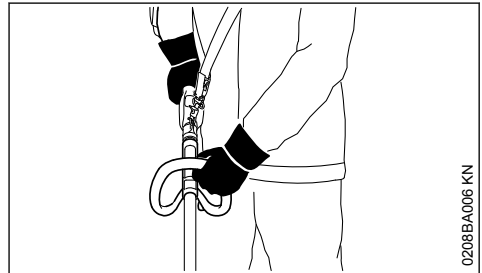

Left hand on loop handle, right hand on control handle, even if you are left-handed.

2.7 While working

Make sure you always have a firm and secure footing.

In the event of impending danger or in an emergency, shut off the engine immediately – move the stop switch / slide control in the direction of 0.

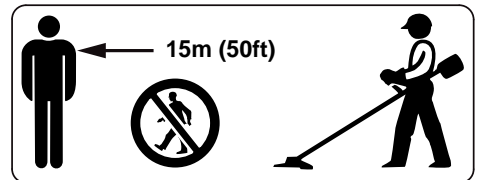

There is a risk of accident due to ejected objects within a wide area around the working space, so ensure there is no-one within a 15 m radius of the tool. This distance must also be maintained in relation to objects (vehicles, window panes) – **risk of property damage!** Even at a distance over 15 m, danger cannot be ruled out.

Check that the engine is properly idling so that the cutting tool will not continue rotating after you release the throttle trigger.

Check and correct the idle speed setting at regular intervals. If the cutting attachment still rotates at idle speed, have your dealer make proper adjustments or repairs. STIHL recommends you have this work done by a STIHL servicing dealer.

Take special care in slippery conditions – **damp, snow, ice**, on slopes or uneven ground.

Watch out for obstacles: tree stumps, roots – **risk of tripping or stumbling!**

Only work while standing on the ground, never on a ladder, work platform or other unstable surface.

Be particularly alert and cautious when wearing hearing protection because your ability to hear warnings (shouts, alarms, etc.) is restricted.

Take breaks when you start getting tired or feeling fatigue – **risk of accidents!**

Work calmly and carefully – in daylight conditions and only when visibility is good. Proceed with caution, do not put others in danger.



As soon as the engine is running, the power machine generates toxic exhaust gas. As soon as the engine is running, the power machine generates toxic exhaust gas. These gases may be odorless and invisible and may contain unburned hydrocarbons and benzene. Never run the engine indoors or in poorly ventilated locations, even if your model is equipped with a catalytic converter.

To reduce the risk of **serious or fatal injury from breathing toxic fumes**, ensure proper ventilation when working in trenches, hollows or other confined locations.

Stop work immediately if you start suffering from nausea, headaches, impaired vision (e.g. your field of vision gets smaller), impaired hearing, dizziness, or impaired concentration – these symptoms may possibly be the result of too-high exhaust gas concentration – **Risk of accidents!**

Operate your power tool so that it produces a minimum of noise and emissions – do not run the engine unnecessarily, accelerate the engine only when working.

To reduce the risk of fire, do not smoke while operating or standing near your power tool. Combustible fuel vapor may escape from the fuel system.

Dust, fumes and smoke produced while working may be hazardous to your health. Wear respiratory protection in case of heavy dust or smoke emission.

If your power tool is subjected to unusually high loads for which it was not designed (e.g. heavy impact or a fall), always check that it is in good condition before continuing work – see also "Before Starting".

Check in particular that the fuel system has no leaks and the safety equipment is fully operative. Never use a power tool that is no longer safe to operate. In case of doubt, contact a dealer.



To reduce the risk of injury from thrown objects, never operate the unit without the proper deflector for the type of cutting attachment being used.



Check the work site – rocks, metal objects etc. may be caught up and ejected – possibly over a distance of 15 m – **risk of injury!** – They can also damage the cutting attachment and other property (e. g. parking vehicles, windows).

Be particularly careful when working on difficult, densely grown terrain.

When mowing in high shrubbery, under shrubbery and hedges: Hold the cutting tool at a working height of at least 15 cm – avoid risks to animals.

Always shut off the engine before leaving the unit unattended.

Examine the cutting attachment periodically at short intervals and as soon as you note any noticeable changes:

- Stop the engine, hold the machine securely, allow the cutting attachment to come to a stop
- Check condition and secure fitting; watch out for cracks
- Ensure that the cutting blades are sharp
- Replace damaged or blunt cutting attachments immediately, even in the event of minor hair-line cracks

Clean grass and plant residue off the cutting attachment mounting at regular intervals – remove any build up of material from the cutting attachment and deflector.

To reduce the risk of injury, shut off the engine before replacing the cutting attachment.



The gearbox gets hot during operation. Never touch the gearbox – **risk of burns!**

Do not continue using or attempt to repair damaged or cracked cutting attachments by welding, straightening or modifying the shape (out of balance).

Particles or pieces may come off and hit the operator or a bystander at a high speed – **risk of most severe injuries!**

If a rotating cutting attachment touches a rock or another hard object, sparks may be generated which may possibly ignite combustible materials. Also dried-out plants and brushwood are combustible, above all in hot and dry weather. If there is a risk of fire, do not use cutting attachments in the vicinity of combustible materials, dried-out plants or brushwood. It is mandatory that you ask the responsible forestry office about any fire hazard conditions.

2.8 Using mowing heads

Extend the cutting attachment deflector with the attached parts specified in the User Manual.

Only use a deflector with a properly fitted blade, to limit the mowing line to the permissible length.

To adjust the mowing line in manually adjustable mowing heads, always switch off the engine first – **risk of injury!**

Misuse with mowing lines that are too long reduces the working speed of the engine. The constant slipping of the clutch causes overheating and damage to important components (e. g. clutch, plastic housing parts) – e. g. due to the cutting attachment rotating during idling – **risk of injury!**

2.9 When using metal cutting attachments

STIHL recommends the use of original STIHL metal cutting attachments. These have been optimized for the machine and the user's requirements.

Metal cutting attachments rotate very fast, generating forces acting on the attachments and on the cuttings.

Metal cutting attachments must be sharpened in regular intervals in accordance with the instructions.

Unevenly sharpened metal cutting attachments generate an imbalance which may cause extreme loads on the machine – **risk of breakage!**

Dull or improperly sharpened cutting edges can put a higher load on the cutting attachment and increase the **risk of injury** from cracked or broken parts.

After each contact of the metal cutting attachment with hard objects (e.g. stones, rocks, metal parts), check it for damage (e.g. tears and deformation). Burrs and other visible accumulated material must be removed since it may come loose at any time while the machine is running and then be ejected – **risk of injury!**

To reduce the above-specified risks involved in operating a metal cutting attachment, ensure that the diameter of your metal cutting attachment is not too big. Also, the attachment must not be too heavy. It must be made of high-quality materials and have a suitable geometry (shape, thickness).

A metal cutting attachment not made by STIHL must not have a different weight, thickness, shape or a larger diameter than the largest STIHL metal cutting attachment approved for this metal cutting attachment – **risk of injury!**

2.10 Vibrations

Prolonged use of the power tool may result in vibration-induced circulation problems in the hands (whitefinger disease).

No general recommendation can be given for the length of usage because it depends on several factors.

The period of usage is prolonged by:

- Hand protection (wearing warm gloves)
- Work breaks

The period of usage is shortened by:

- Any personal tendency to suffer from poor circulation (symptoms: frequently cold fingers, tingling sensations).
- Low outside temperatures.
- The force with which the handles are held (a tight grip restricts circulation).

Continual and regular users should monitor closely the condition of their hands and fingers. If any of the above symptoms appear (e.g. tingling sensation in fingers), seek medical advice.

2.11 Maintenance and Repairs

Service the machine regularly. Do not attempt any maintenance or repair work not described in the instruction manual. Have all other work performed by a servicing dealer.

STIHL recommends that you have servicing and repair work carried out exclusively by an authorized STIHL servicing dealer. STIHL dealers are regularly given the opportunity to attend training courses and are supplied with the necessary technical information.

Only use high-quality replacement parts in order to avoid the risk of accidents and damage to the machine. If you have any questions in this respect, consult a servicing dealer.

STIHL recommends the use of original STIHL replacement parts. They are specifically designed to match your model and meet your performance requirements.

To reduce the risk of injury from unintentional engine startup, **always shut off the engine and disconnect the spark plug boot** before performing any repairs, maintenance or cleaning work. – Exception: Carburetor and idle speed adjustments.

Do not turn the engine over on the starter with the spark plug boot or spark plug removed since there is otherwise a **risk of fire** from uncontained sparking.

To reduce the **risk of fire**, do not service or store your machine near open flames.

Check the fuel filler cap for leaks at regular intervals.

Use only a spark plug of the type approved by STIHL and make sure it is in good condition – see "Specifications".

Inspect the ignition lead (insulation in good condition, secure connection).

Check the condition of the muffler.

To reduce the **risk of fire and damage to hearing**, do not operate your machine if the muffler is damaged or missing. –

Do not touch a hot muffler since **burn injury** will result.

Vibration behavior is influenced by the condition of the AV elements – check the AV elements at regular intervals.

2.12 Symbols on Deflectors

An **arrow** on the deflector shows the correct direction of rotation of the cutting attachments.

Some of the following symbols are applied to the outside of the deflector to indicate the approved combination of cutting attachment and deflector.



Deflector may be used with mowing heads.



Deflector must not be used with mowing heads.



Deflector may be used with grass cutting blades.



Deflector must not be used with grass cutting blades.



Deflector may be used with brush knives.



Deflector must not be used with brush knives.



Deflector must not be used with shredder blades.



Deflector must not be used with circular saw blades.

2.13 Shoulder strap

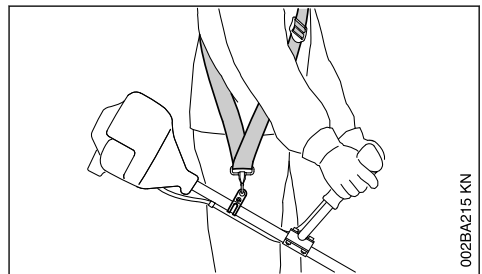

► Use a shoulder strap.

- ▶ With the engine running, attach the machine to the shoulder strap.

Grass cutting blades must always be used in combination with a shoulder strap.

2.14 Mowing Head with Nylon Line

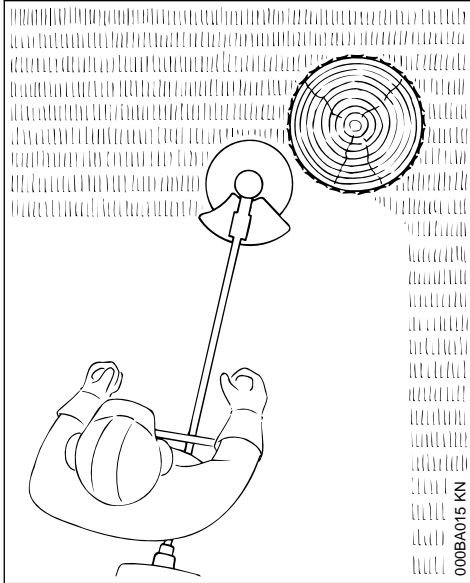

Nylon line achieves a soft cut for edging and trimming around trees, fence posts, etc. – less risk of damaging tree bark.

The mowing head comes with an instruction leaflet. Refill the mowing head with nylon line as described in the instruction leaflet.

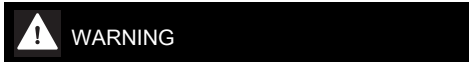

To reduce the risk of serious injury, never use wire or metal-reinforced line in place of the nylon line.

2.15 STIHL Polycut Mowing Head with Polymer Blades

For mowing unobstructed edges of meadows (without posts, fences, trees or similar obstacles).

Check the wear limit marks!

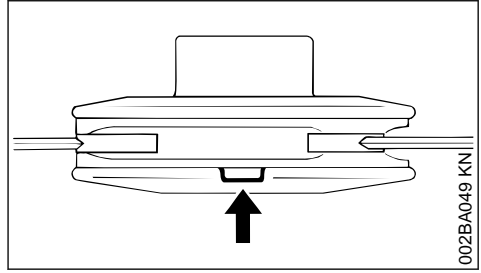

If one of the wear limit marks on the PolyCut mowing head is worn through (arrow): Do not continue using the mowing head. Install a new one. There is otherwise a **risk of injury** from thrown parts of the head.

It is important to follow the maintenance instructions for the PolyCut mowing head.

The PolyCut can also be equipped with mowing line in place of the polymer blades.

The mowing head comes with instruction leaflets. Equip the mowing head with polymers blades or nylon line as described in the instruction leaflets.



Never use wire in place of the nylon mowing line – **risk of injury**.

2.16 Risk of Kickout (Blade Thrust) with Metal Cutting Attachments

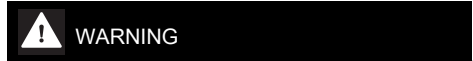

When using metal cutting attachments there is a risk of kickout when the rotating blade comes into contact with a solid object such as a tree trunk, branch, tree stump, rock or similar. The machine is thrown to the right or to the rear – opposite to the attachment's direction of rotation.

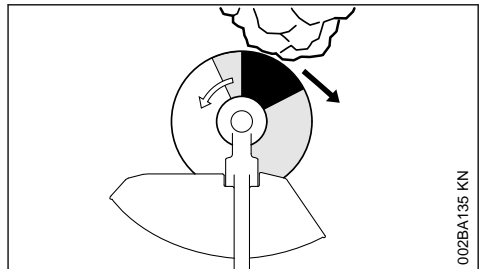

The **risk of kickout is greatest** when the **black area** of the rotating cutting attachment comes into contact with a solid object.

2.17 Grass Cutting Blade

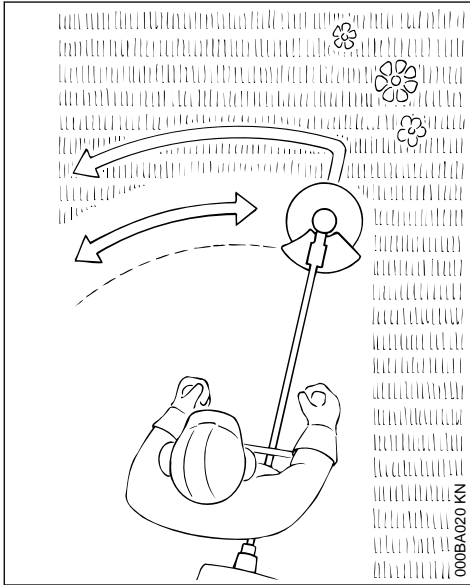





Use for grass and weeds only – sweep the brushcutter in an arc like a scythe.

! WARNING

Improper use may damage the grass cutting blade – **risk of injury** from thrown parts.

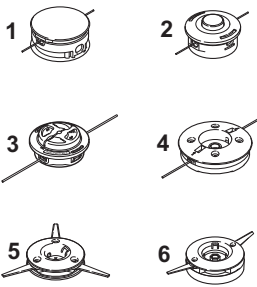
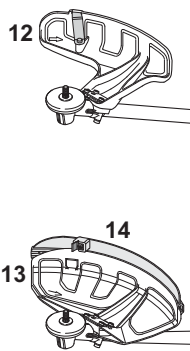
Resharpener the grass cutting blade according to instructions when it has dulled noticeably.

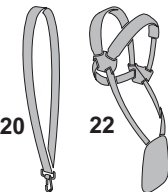
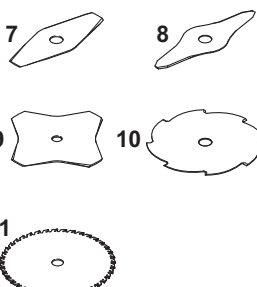
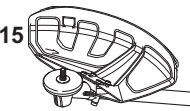
3 Approved Combinations of Cutting Attachment, Deflector, Handle and Harness

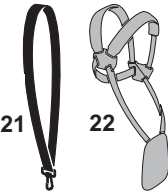
Cutting attachment	Deflector	Handle	Carrying strap
			
			

3.1 Permissible combinations

Choose the correct combination from the table depending on the cutting tool!

! WARNING

For safety reasons only the cutting attachments, deflector, handle and harness versions within one line of the table may be combined with one another. No other combinations are permitted because of the **risk of accidents**.

3.2 Cutting attachments

3.2.1 Mowing heads

- 1 STIHL SuperCut 20-2
- 2 STIHL AutoCut 25-2/AutoCut 27-2
- 3 STIHL AutoCut C 26-2

- 4 STIHL DuroCut 20-2

- 5 STIHL PolyCut 20-3

- 6 STIHL PolyCut 28-2

3.2.2 Metal cutting tools

- 7 Grass cutting blade 230-2 (230 mm dia.)

- 8 Grass cutting blade 260-2 (260 mm dia.)

- 9 Grass cutting blade 230-4 (230 mm dia.)

- 10 Grass cutting blade 230-8 (230 mm dia.)

- 11 Grass cutting blade 250-32 (250 mm dia.)

! WARNING

Grass cutting blades of materials other than metal must not be used.

3.3 Deflectors

12 Deflector for mowing heads

13 Deflector with

14 Skirt and blade for mowing heads

15 Deflector without skirt and blade for metal mowing heads

3.4 Handles

16 Loop handle

17 Loop handle with

18 Barrier bar

19 Bike handle

3.5 Shoulder straps

20 Shoulder strap can be used

21 Shoulder strap must be used

22 Full harness can be used

4 Approved Power Tool Attachments

The following STIHL attachments may be used with the basic power tool:

Attachment	Application
RG ¹⁾	Weeder

5 Mounting the Bike Handle

5.1 Mounting the Handlebar

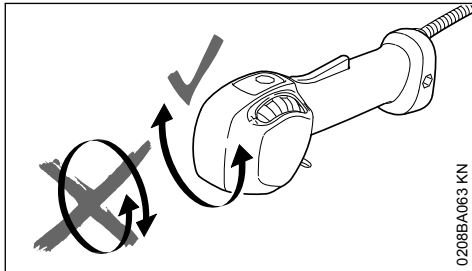

Do not rotate the control handle (1) between unpacking and mounting it on the handlebar.

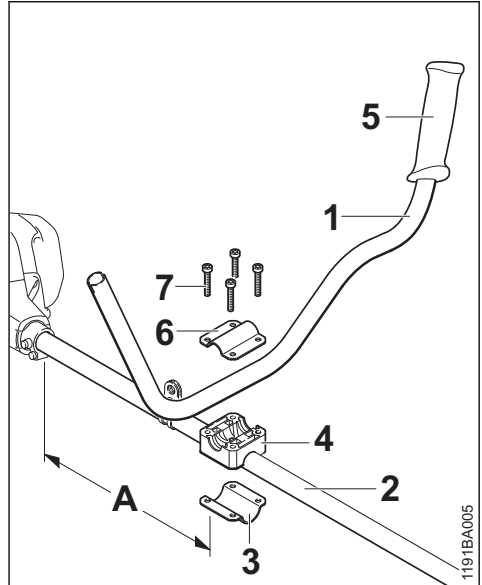

- ▶ Mount the handlebar (1) on the drive tube (2) about 40 cm/15 in (A) forward of the engine housing.
- ▶ Place the clamp (3) and handle support (4) against the drive tube (2).

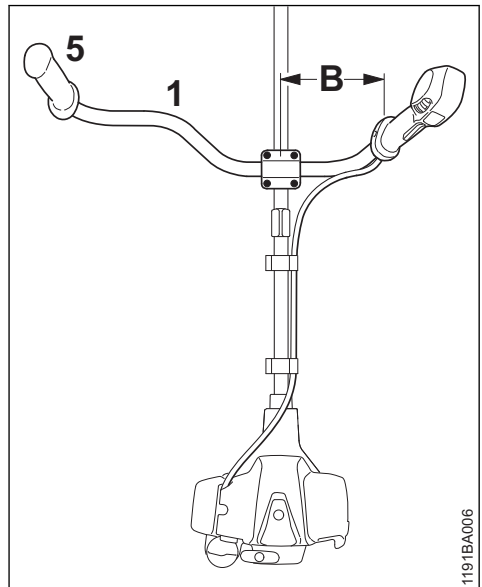

¹⁾ use the barrier bar on machines with loop handle

- ▶ Place the handlebar (1) in the handle support so that distance B is no more than 15 cm (6 in) – the rubber handle (5) must be on the left (viewed from engine).
- ▶ Place the clamp (6) on the handle support.
- ▶ Insert the screws (7) through the holes in the parts and screw them into the clamp (3) as far as stop.
- ▶ Line up the handlebar.
- ▶ Tighten down the screws firmly.

5.2 Mounting the Control Handle

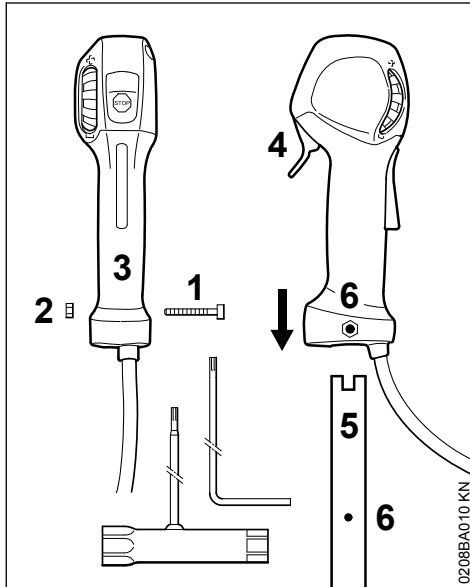

- ▶ Take out the screw (1) – the nut (2) remains in the control handle (3).
- ▶ Push the control handle onto the handlebar (5) until the holes (6) line up – the throttle trigger (4) must point towards the gearbox.
- ▶ Insert the screw (1) and tighten it down firmly.

5.3 Fitting the Throttle Cable

NOTICE

Do not kink the throttle cable or lay it in tight radii – make sure the throttle trigger moves freely.

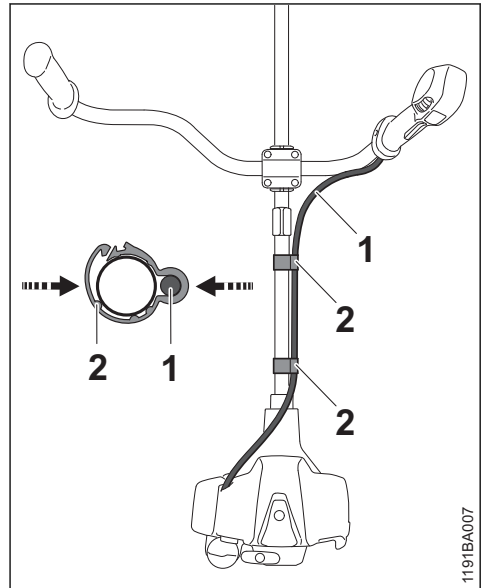

- ▶ Position the throttle cable retainer (2) and throttle cable (1) against the drive tube.
- ▶ Close the throttle cable retainer (2). The retainer (2) snaps into place.

5.4 Adjusting the Throttle Cable

- ▶ Check adjustment of throttle cable – see "Inspection and Maintenance by User".

6 Mounting the Loop Handle

6.1 Using the Barrier Bar

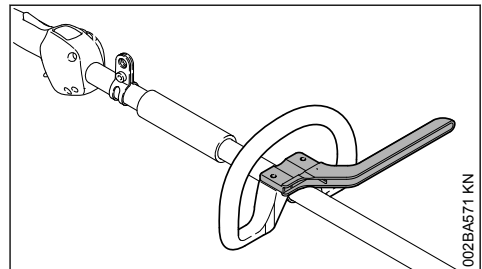

A barrier bar may have to be mounted at the loop handle to suit the tool you intend to use – see

"Approved Combinations of Cutting Attachment, Deflector, Handle and Harness".

The barrier bar is included with the machine or is available as a special accessory.

6.2 Mounting the Loop Handle with Barrier Bar

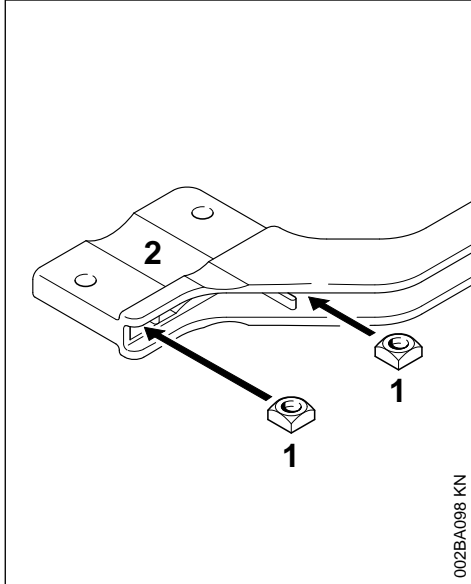

- ▶ Insert the square nuts (1) in the barrier bar (2)
– the holes must line up

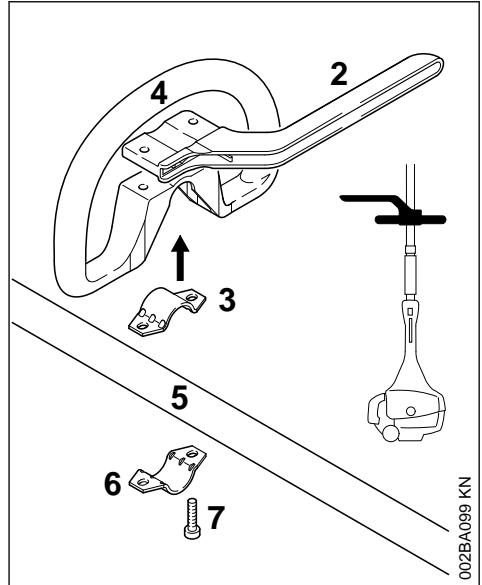

- ▶ Insert the clamp (3) in the loop handle (4) and position them together on the shaft (5)
- ▶ Position the clamp (6) against the shaft
- ▶ Position the barrier bar (2) – note position!
- ▶ Line up the holes
- ▶ Insert the screws (7) in the holes and screw them into the barrier bar as far as they will go
- ▶ Go to "Securing the Loop Handle"

6.3 Mounting the Loop Handle without Barrier Bar

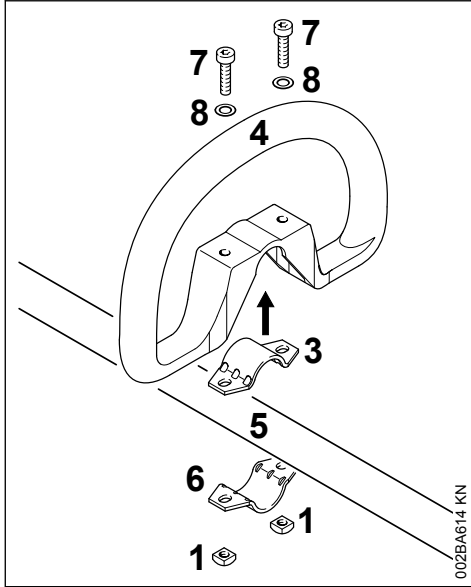

- ▶ Insert the clamp (3) in the loop handle (4) and position them together on the shaft (5)
- ▶ Position the clamp (6) against the shaft
- ▶ Line up the holes
- ▶ Fit the washer (8) on the screw (7) and insert the screw in the hole. Fit the square nuts (1) and screw it down as far as it will go
- ▶ Go to "Securing the Loop Handle"

6.4 Orienting and Securing the Loop Handle

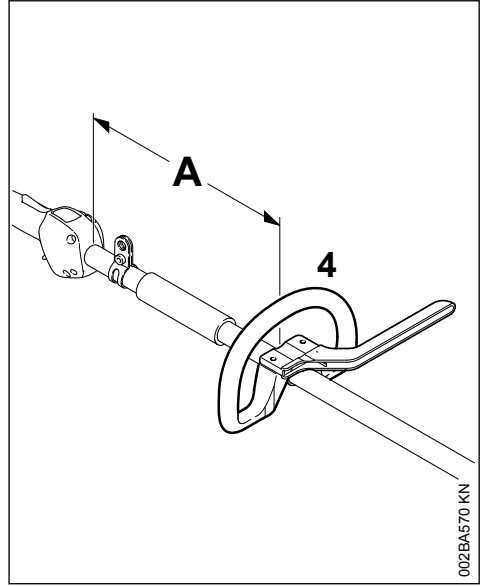

The loop handle can be adjusted to suit the height and reach of the operator and the application by changing distance "A".

Recommendation: distance (A): about 20 cm (8 in)

- ▶ Slide the loop handle to the required position
- ▶ Line up the loop handle (4)
- ▶ Tighten down the screws until the loop handle can no longer be rotated on the shaft. If no barrier bar is fitted – lock the nuts if necessary

7 Fitting the Carrying Ring

7.1 Polymer Version

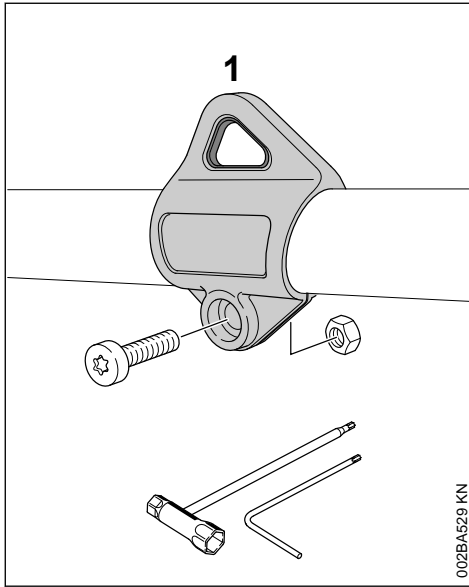

For position of carrying ring see "Main Parts".

- ▶ Push the carrying ring (1) over the drive tube.
- ▶ Insert the M5 nut in the hex recess in the carrying ring.
- ▶ Fit the M5x14 screw.
- ▶ Line up the carrying ring.
- ▶ Tighten down the screw firmly.

8 Mounting the deflector

8.1 Mounting the Deflector

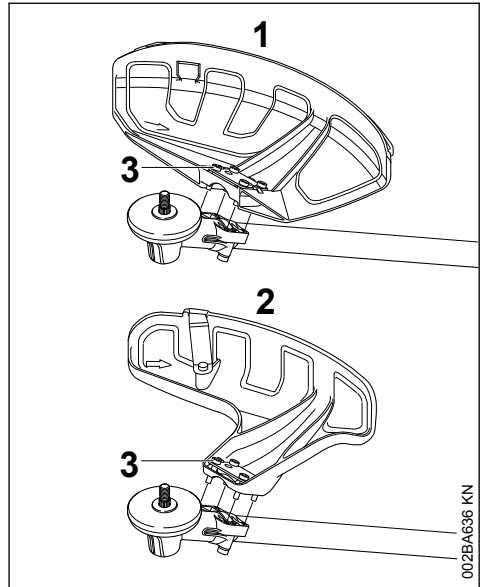

1 Deflector for mowing attachments

2 Deflector for mowing heads

Deflectors (1 and 2) are both mounted to the gearbox in the same way.

- ▶ Place the deflector on the gearbox flange.
- ▶ Insert the screws (3) and tighten them down firmly.

8.2 Fitting the Skirt and Blade



WARNING

Risk of injury from thrown objects and contact with the cutting attachment. These parts must be fitted to the deflector (1) when you use a mowing head.

8.3 Fitting the Skirt

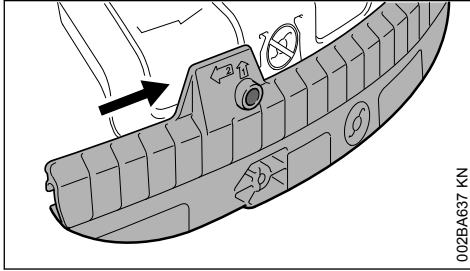

002BA637 KN

- ▶ Slide the lower guide slot of the skirt onto the deflector – it must snap into position.

8.4 Removing the Skirt

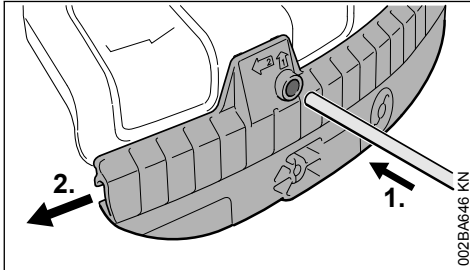

002BA646 KN

- ▶ Insert the stop pin into the hole in the skirt and use it to push the skirt to the left.
- ▶ Pull the skirt off the deflector.

8.5 Mounting the Blade

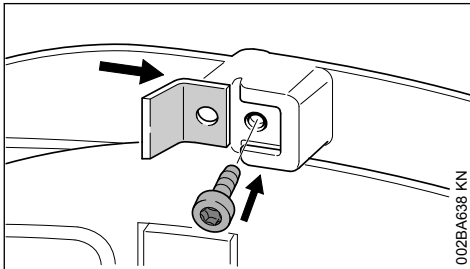

002BA638 KN

- ▶ Slide the line limiting blade into the guide on the skirt.
- ▶ Insert the screw and tighten it down firmly.

9 Mounting the Cutting Attachment

9.1 Placing power tool on the ground

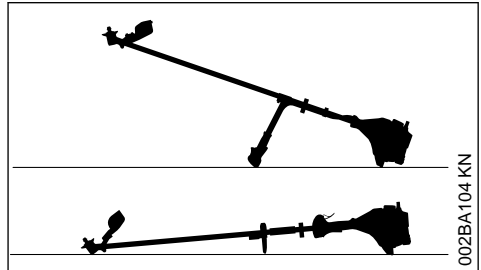

002BA104 KN

- ▶ Shut off the engine.
- ▶ Lay your power tool on its back so that the cutting attachment mounting face is pointing up.

9.2 Mounting Hardware for Cutting Attachments

The mounting hardware supplied depends on the cutting attachment that comes as original equipment with the new machine.

9.2.1 Machine supplied with mounting hardware

Mowing heads and metal cutting attachments may be mounted.

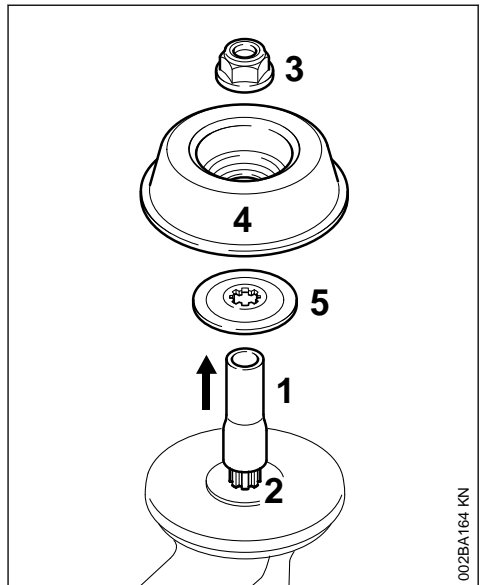

002BA164 KN

Depending on the cutting attachment, it may be necessary to use the nut (3), rider plate (4) and thrust washer (5).

These parts are included in a kit supplied with the machine and are also available as special accessories.

9.2.2 Removing the transport lock

- ▶ Pull the hose (1) off the shaft (2).

9.2.3 Machine supplied without mounting hardware

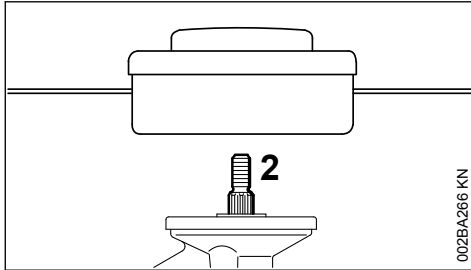

Only mowing heads may be used which mount directly to the shaft (2).

9.3 Blocking the Shaft

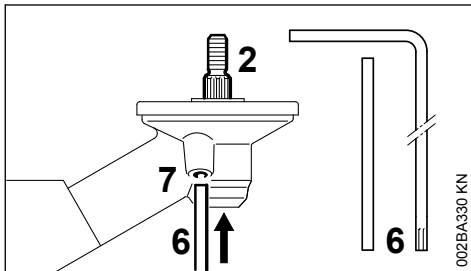

The output shaft (2) must be blocked with the stop pin (6) or screwdriver (6) to mount or remove cutting attachments. These parts come standard with the machine or are available as special accessories.

- ▶ Insert the stop pin (6) or screwdriver (6) in the hole (7) in the gearbox as far as stop – and apply slight pressure.
- ▶ Rotate shaft, nut or cutting attachment until the stop pin slips into position and blocks the shaft.

9.4 Removing the Mounting Hardware

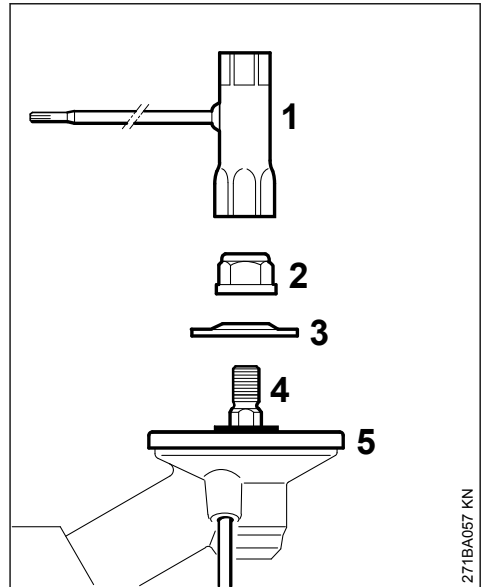

- ▶ Block the shaft.
- ▶ Use the combination wrench (1) to loosen and remove the nut (2) clockwise (left-hand thread).
- ▶ Take the thrust washer (3) off the shaft (4). Do not remove the thrust plate (5).

9.5 Mounting the Cutting Attachment



WARNING

Use a deflector that matches the cutting attachment – see "Mounting the Deflector".

9.6 Fitting the mowing head with screw mounting

Keep the supplement sheet for the mowing head in a safe place.

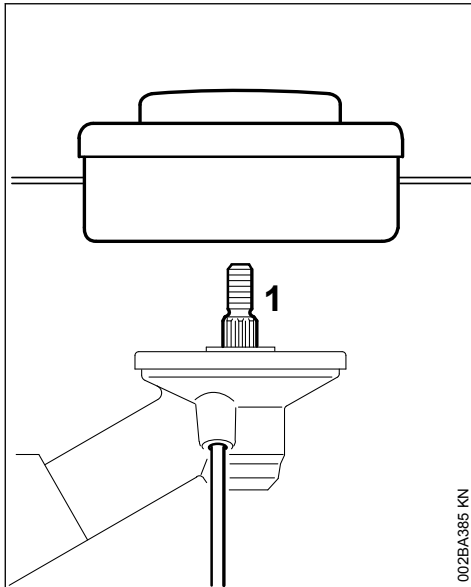

002BA385 KN

- ▶ Fit the thrust plate
- ▶ Turn the mowing head anticlockwise on the shaft (1) as far as it will go
- ▶ Retain the shaft
- ▶ Tighten the mowing head

NOTICE

Remove the tool that was used to block the shaft.

9.7 Removing the Mowing Head

- ▶ Retain the shaft
- ▶ Turn the mowing head clockwise

9.8 Mounting Metal Cutting Attachment

Keep the leaflet and packaging of the metal cutting tool in a safe place.

! WARNING

Wear protective gloves to reduce the risk of direct contact with the sharp cutting edges.

Mount only metal cutting attachments.

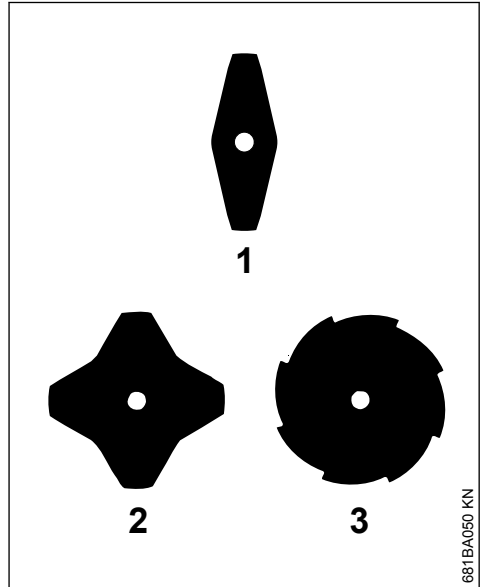
Check direction of rotation of cutting attachment

681BA050 KN

The cutting edges of the grass cutting blades (1) and (2) may point in either direction – these cutting attachments must be turned over regularly to reduce one-sided wear.

Cutting edges of grass cutting blade (3) must point clockwise.

! WARNING

Direction of rotation is indicated by an arrow on the inside of the deflector.

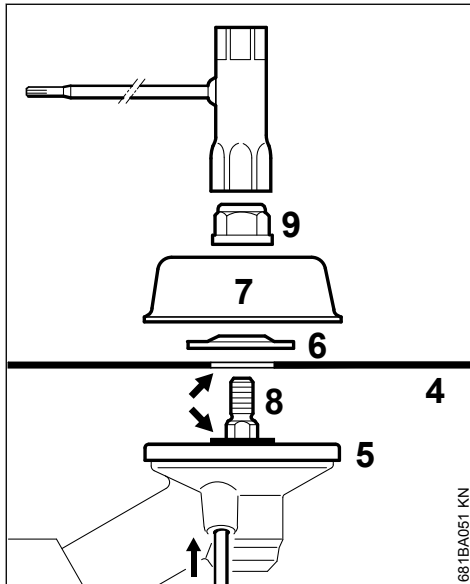

- ▶ Place the cutting attachment (4) on the thrust plate (5).

! WARNING

Collar (see arrow) must engage the cutting attachment's mounting hole.

Securing the cutting attachment

- ▶ Fit the thrust washer (6) – convex side must face up.
- ▶ Fit the rider plate (7).
- ▶ Block the shaft (8).
- ▶ Screw the mounting nut (9) on to the shaft counterclockwise and tighten it down firmly.

! WARNING

If the mounting nut has become too loose, fit a new one.

NOTICE

Remove the tool used to block the shaft.

9.9 Removing the Metal Cutting Attachment

! WARNING

Wear protective gloves to reduce the risk of direct contact with the sharp cutting edges.

- ▶ Block the shaft.
- ▶ Unscrew the mounting nut clockwise.
- ▶ Remove cutting attachment and its mounting hardware from the gearbox – but **do not** remove the thrust plate (5).

10 Fuel

The engine requires a mixture of gasoline and engine oil.

! WARNING

Avoid direct skin contact with fuel and breathing in of gasoline fumes.

10.1 STIHL MotoMix

STIHL recommends using STIHL MotoMix. This pre-blended fuel is free of benzene and lead, is distinguished by a high octane rating, and always provides the proper mixing ratio.

STIHL MotoMix uses STIHL HP Ultra two-stroke engine oil for optimum engine life.

MotoMix is not available in all markets.

10.2 Mixing fuel

NOTICE

Unsuitable fuels or a mixing ratio that deviates from the specification can lead to severe engine damage. The engine, seals, fuel lines and fuel tank may be damaged if low-quality gasoline or engine oil is used.

10.2.1 Gasoline

Use only **high-quality gasoline** with an octane rating of at least 90 ROC – leaded or unleaded.

Gasoline with an alcohol component exceeding 10% can cause impaired engine performance in engines with manually adjustable carburetors and thus should not be used in these engines.

Engines with M-Tronic deliver full engine performance using gasoline with an alcohol component of up to 27% (E27).

10.2.2 Engine oil

If you mix the fuel yourself, use only STIHL two-stroke engine oil or another high-performance engine oil classified as JASO FB, JASO FC, JASO FD, ISO-L-EGB, ISO-L-EGC or ISO-L-EGD.

STIHL specifies STIHL HP Ultra two-stroke engine oil or an equivalent high-performance engine oil in order to maintain emission limits over the machine's service life.

10.2.3 Mixing ratio

with STIHL two-stroke engine oil 1:50; 1:50 = 1 part oil + 50 parts gasoline

10.2.4 Examples

Quantity of gasoline	STIHL two-stroke engine oil 1:50	
Liters	Liters	(ml)
1	0.02	(20)
5	0.10	(100)
10	0.20	(200)
15	0.30	(300)
20	0.40	(400)
25	0.50	(500)

- ▶ Pour oil into an approved safety fuel canister first, then add gasoline and mix thoroughly

10.3 Storing fuel mixture

Store in approved safety fuel canisters only in a dry, cool and secure place protected against light and sunlight.

Fuel mixture deteriorates with age – mix only as much as needed for a few weeks. Do not store fuel mixture for longer than 30 days. The fuel mixture can become unusable more quickly if exposed to light, sunlight or low or high temperatures.

STIHL MotoMix however can be stored for up to 5 years without any problems.

- ▶ Shake the canister containing the fuel mixture thoroughly before refueling

! WARNING

Pressure may have built up in the canister – open it carefully.

- ▶ The fuel tank and the canister in which fuel mixture is stored should be cleaned thoroughly from time to time

Residual fuel and the liquid used for cleaning must be disposed of in accordance with regulations and without harming the environment!

11 Fueling

11.1 Fuel filler cap

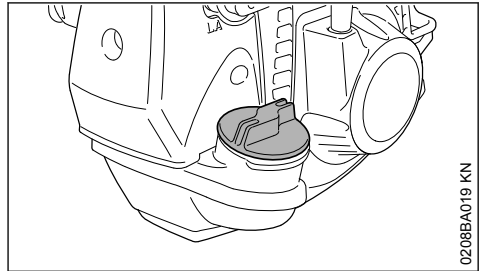

0208BA019 KN

! WARNING

When fueling on a slope, always position the machine with the filler cap facing uphill.

- ▶ Place the machine on level ground so that the filler cap is facing up.
- ▶ Before fueling, clean the filler cap and the area around it to ensure that no dirt falls into the tank.

11.2 Open the tank cap.

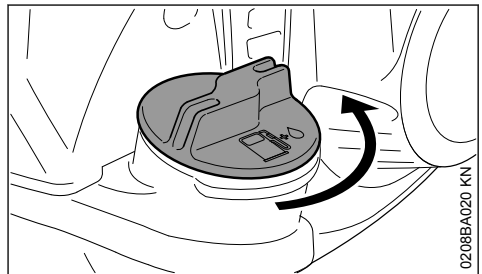

0208BA020 KN

- ▶ Turn the cap counterclockwise until it can be removed from the tank opening.
- ▶ Remove the cap.

11.3 Filling up with fuel

Take care not to spill fuel while fueling and do not overfill the tank.

STIHL recommends you use the STIHL filler nozzle for fuel (special accessory).

- ▶ Fill up with fuel.

11.4 Close the tank cap.

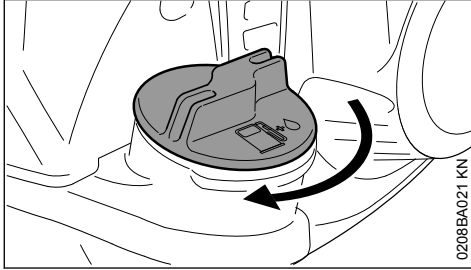

- ▶ Place the cap in the opening.
- ▶ Turn the cap clockwise as far as stop and tighten it down as firmly as possible by hand.

12 Fitting the Harness

The type and style of the harness depend on the market.

The use of the shoulder strap is described in the chapter on "Approved Combinations of Cutting Attachment, Deflector, Handle and Harness".

12.1 Shoulder strap

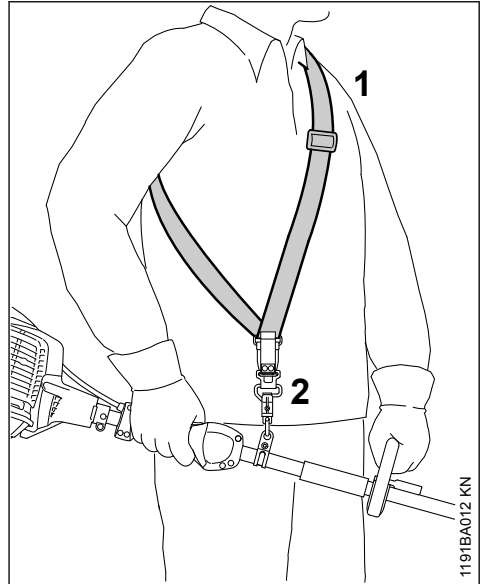

- ▶ Put on the shoulder strap (1).
- ▶ Adjust the length of the strap so that the carabiner (2) is about a hand's width below your right hip.
- ▶ Balance the machine.

12.2 Full Harness

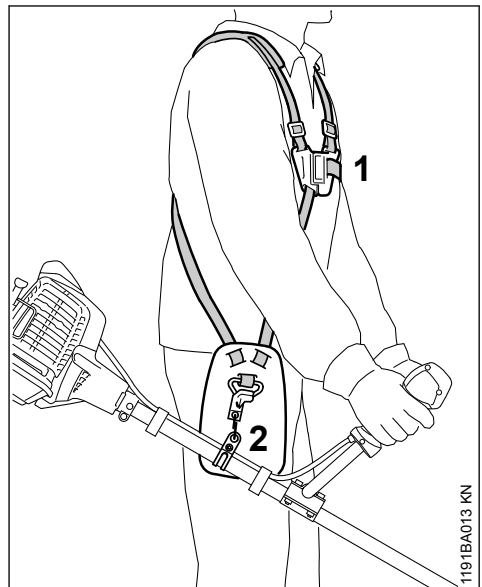

- ▶ Put on the full harness (1).
- ▶ Adjust the length of the strap so that the carabiner (2) is about a hand's width below your right hip.
- ▶ Balance the machine.

12.3 Attaching Machine to Harness

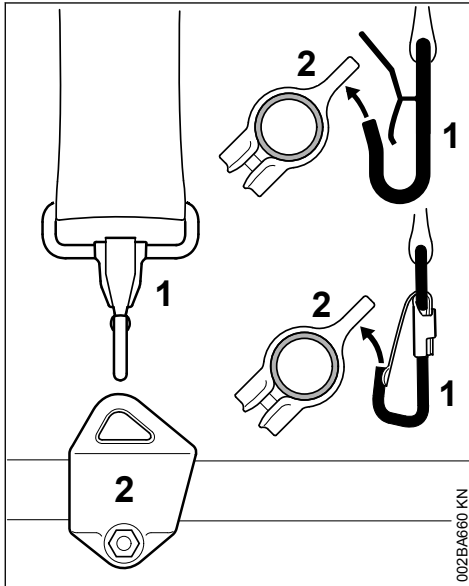

The type and style of the harness and carabiner (spring hook) depend on the market.

- ▶ Attach the carabiner (1) to the carrying ring (2) on the drive tube.

12.4 Disconnecting Machine from Harness

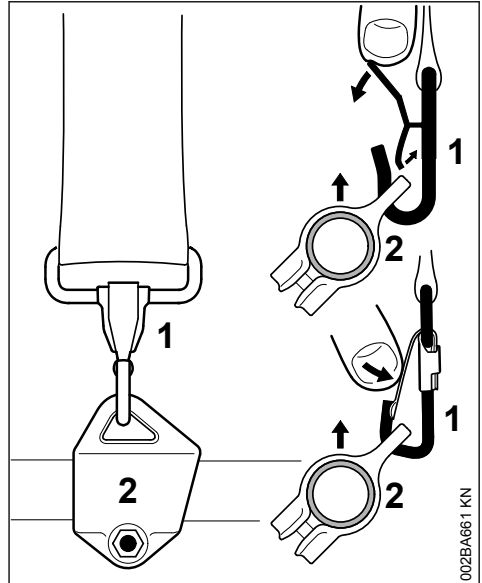

- ▶ Press down the bar on the carabiner (1) and pull the carrying ring (2) out of the carabiner.

12.5 Throwing Off the Machine



The machine must be quickly thrown off in the event of imminent danger. Practice removing and putting down the machine as you would in an emergency. To avoid damage, do not throw the unit to the ground when practicing.

Practice quickly detaching the power tool from the carabiner as described under "Disconnecting Machine from Harness".

If you are using a shoulder strap: Practice slipping the strap off your shoulder.

If you are using a full harness: Practice quickly opening the locking plate and slipping the harness straps off your shoulders.

13 Balancing the Machine

13.1 Balancing the Machine

The unit is balanced differently depending on the cutting attachment used.

Proceed as follows until the conditions specified under "Balanced positions" have been met:

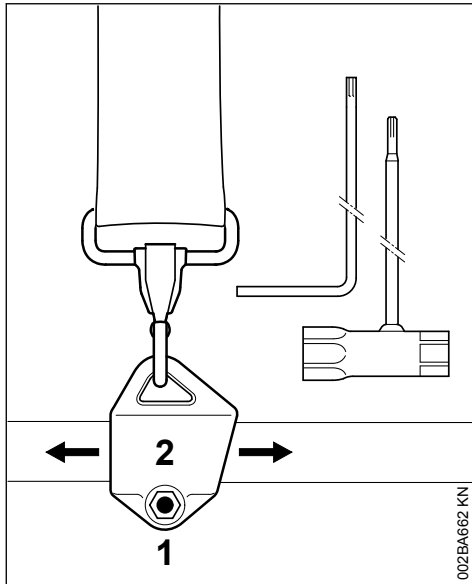

- ▶ Loosen the screw (1).
- ▶ Slide the carrying ring (2) along the drive tube.
- ▶ Tighten the screw moderately.
- ▶ Allow the unit to hang freely.
- ▶ Check the position obtained.

Balanced positions

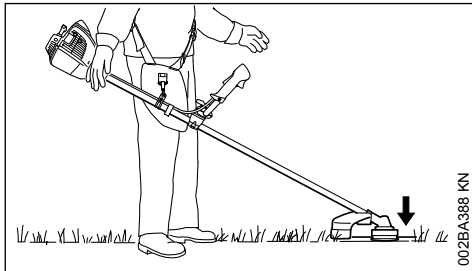

Mowing tools such as mowing heads, grass cutting blades and brush knives

- ▶ should just touch the ground.

When the correct balanced position has been reached:

- ▶ Tighten down the screw on the carrying ring firmly.

14 Starting / Stopping the Engine

14.1 Controls

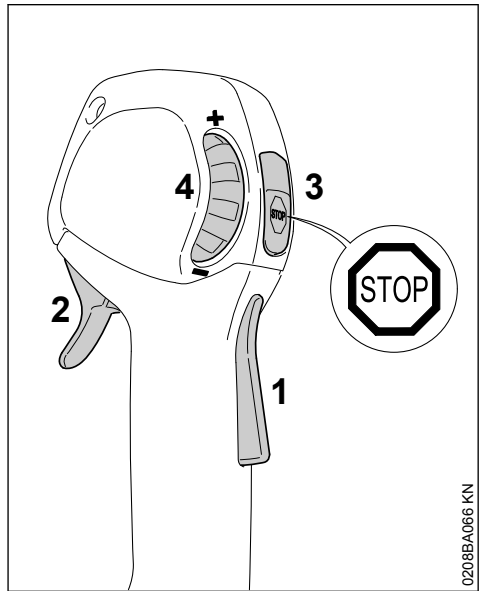

- 1 Throttle trigger lockout
- 2 Throttle trigger
- 3 Stop switch with Run and Stop positions. Depress the stop switch (⊖) to switch off the ignition – see "Function of Stop Switch and Ignition System".
- 4 Throttle set wheel – limits travel of throttle trigger – see "Function of throttle set wheel".

14.1.1 Function of Stop Switch and Ignition System

The ignition is switched off and the engine stopped when the stop switch is pressed. The stop switch returns automatically to the **Run** position when it is released: The ignition is switched on again after the engine stops – the engine is then ready to start.

14.1.2 Function of Throttle Set Wheel

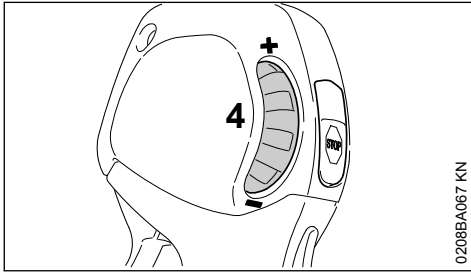

0208BA067 KN

The throttle set wheel (4) enables the travel of the throttle trigger to be preset anywhere between idle and full throttle.

- Turn throttle set wheel (4) in direction of – to reduce throttle trigger travel and maximum engine speed.
- Turn throttle set wheel (4) in direction of + to increase throttle trigger travel and maximum engine speed.
- It is possible to override the preset stop and open the throttle wide by pulling the throttle trigger firmly – the preset stop remains unaffected. The original setting is restored when the throttle trigger is released.

14.2 Starting the Engine

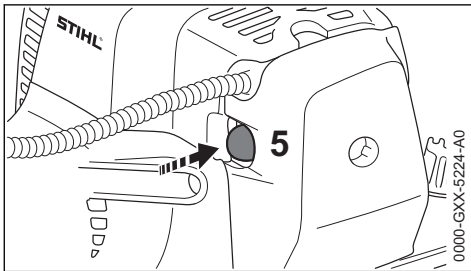

0000-GXX-5224-A0

- ▶ Press the manual fuel pump bulb (5) at least five times – even if the bulb is already filled with fuel.

Cold engine (cold start)

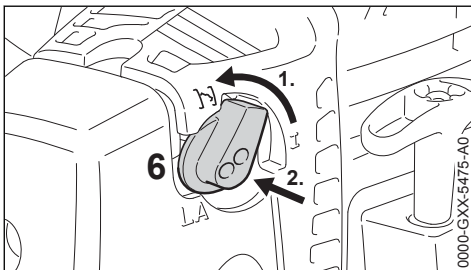

0000-GXX-5475-A0

- ▶ Turn choke knob (6) and then push it in at **I**
- Also use this setting if the engine has been running but is still cold.
- Turn throttle set wheel in direction of + as far as stop.

Hot engine (hot start)

- ▶ Choke knob (6) remains in **I** position.

14.2.1 Cranking

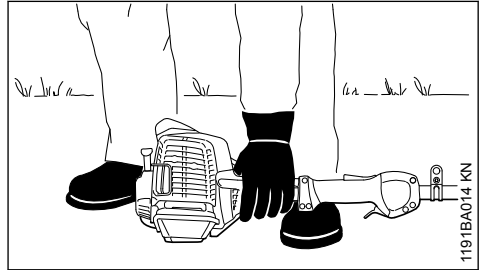

1191BA014 KN

- ▶ Place the machine on the ground: It must rest securely on the engine support and the deflector.
- ▶ If fitted: Remove the transport guard from the cutting attachment.

To reduce the risk of accidents, check that the cutting attachment is not touching the ground of any other obstacles.

- ▶ Make sure you have a firm footing, either standing, stooping or kneeling.
- ▶ Hold the unit **firmly** on the ground with your left hand and press down – do not touch the throttle trigger, lockout lever or stop switch.

NOTICE

Do not stand or kneel on the shaft.

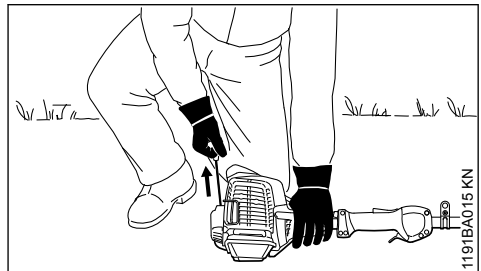

1191BA015 KN

- ▶ Hold the starter grip with your right hand.

14.2.2 Version without ErgoStart

- ▶ Pull the starter grip slowly until you feel it engage and then give it a brisk strong pull.

14.2.3 Version with ErgoStart (C-E)

- ▶ Pull the starter grip slowly and steadily.

NOTICE

Do not pull out the starter rope all the way – **it might otherwise break.**

- ▶ Do not let the starter grip snap back. Guide it slowly back into the housing so that the starter rope can rewind properly.
- ▶ Continue cranking until the engine runs.

14.2.4 As soon as the engine runs

At temperatures below +10°C

Warm up the engine for at least 10 seconds in position **I**.

At temperatures above +10°C

Warm up the engine for at least 5 seconds in position **I**.

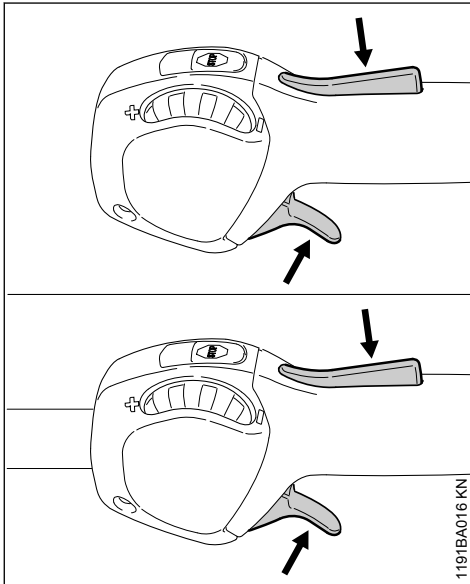

- ▶ Depress throttle trigger lockout and pull the throttle trigger – the choke knob moves to the Run **I** position.

Warm up a **cold engine** at varying speeds.



WARNING

Make sure the carburetor is correctly adjusted. The cutting attachment must not rotate when the engine is idling.

Your machine is now ready for operation.

14.3 Stopping the Engine

- ▶ Depress the momentary contact stop switch – the engine stops – release the stop switch – it springs back to the run position.

14.4 Other Hints on Starting

Engine stalls in cold start position **I**.

- ▶ Depress throttle trigger lockout and pull the throttle trigger – the choke knob moves to the Run **I** position.
- ▶ Continue cranking in position **I** until the engine runs.

Running engine stalls in cold start position **I** or under acceleration.

- ▶ Continue cranking in position **I** until the engine runs.

If the engine does not start

- ▶ Check that all settings are correct.
- ▶ Check that there is fuel in the tank and refuel if necessary.
- ▶ Check that the spark plug boot is properly connected.
- ▶ Repeat the starting procedure.

Engine is flooded

- ▶ Move the choke knob to **I** and continue cranking until the engine runs.

Fuel tank run until completely dry

- ▶ After refueling, depress the manual fuel pump bulb at least five times – even if the bulb is already filled with fuel.
- ▶ Set the choke knob according to engine temperature.
- ▶ Now start the engine.

15 Transporting the Unit

15.1 Using Transport Guard

The type of transport guard depends on the metal cutting attachment supplied with the machine. Transport guards are available as special accessories.

15.1.1 230 mm grass cutting blades

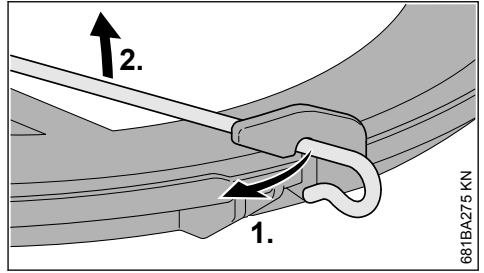
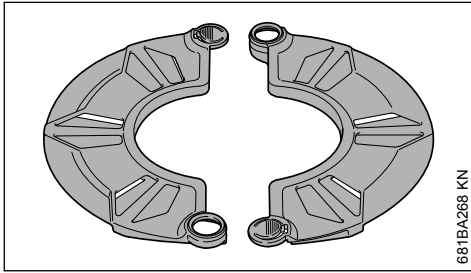

- ▶ Disconnect wire rod from the transport guard.
- ▶ Swing wire rod outwards.

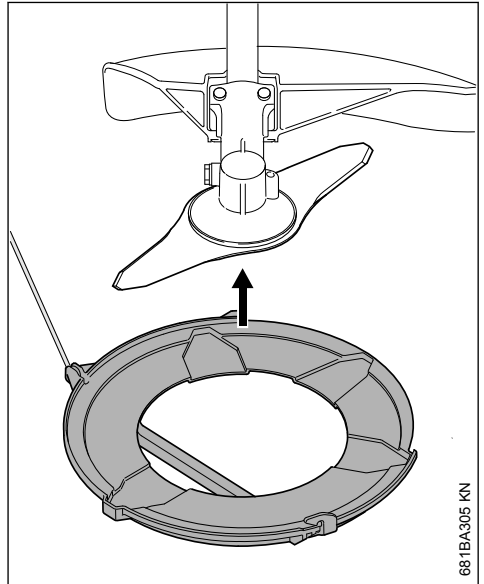
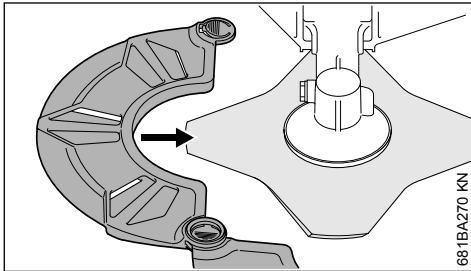
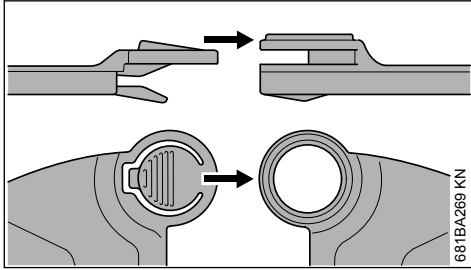

15.1.2 Grass Cutting Blades up to 260 mm

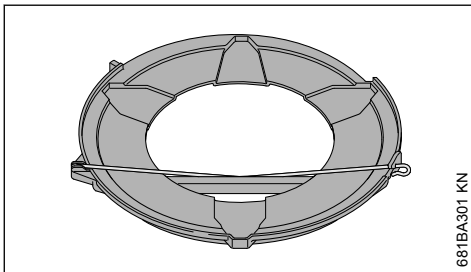

- ▶ Fit the transport guard on the cutting attachment from below.

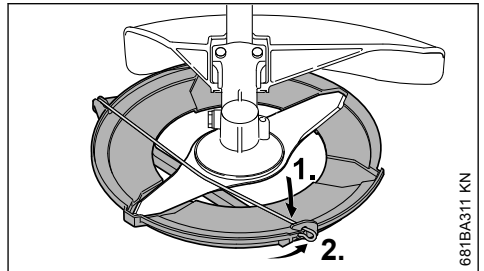

- ▶ Hook wire rod to the transport guard.
- ▶ Swing wire rod into position.

16 Operating Instructions

16.1 During break-in period

A factory-new machine should not be run at high revs (full throttle off load) for the first three tank fillings. This avoids unnecessary high loads during the break-in period. As all moving parts have to bed in during the break-in period, the frictional resistances in the engine are greater during this period. The engine develops its maximum power after about 5 to 15 tank fillings.

16.2 During Operation

After a long period of full throttle operation, allow the engine to run for a short while at idle speed so that engine heat can be dissipated by the flow of cooling air. This protects engine-mounted components (ignition, carburetor) from thermal overload.

16.3 After Finishing Work

Storing for a short period: Wait for the engine to cool down. Empty the fuel tank and keep the machine in a dry place, well away from sources of ignition, until you need it again. For longer out-of-service periods – see "Storing the Machine".

17 Cleaning the Air Filter

17.1 If there is a noticeable loss of engine power

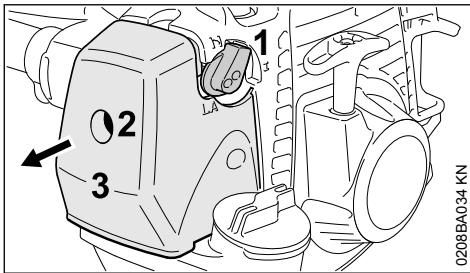

- ▶ Set knob for warm start (1) to **I**
- ▶ Turn screw (2) in filter cover (3) counterclockwise until the cover is loose
- ▶ Remove filter cover (3)
- ▶ Clean away loose dirt from around the filter

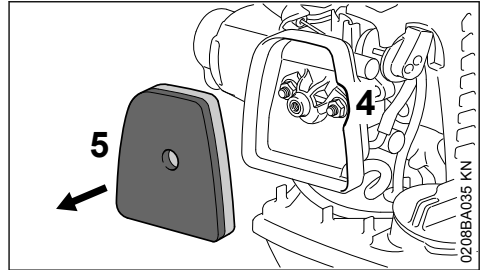

- ▶ Grip into the recess (4) in the filter housing and remove the felt filter (5)
- ▶ Replace felt filter (5) – as a temporary measure you can knock it out on the palm of your hand or blow it out with compressed air – do not wash

NOTICE

Replace any damaged parts!

- ▶ Insert felt filter (5) form-fittingly into the filter housing
- ▶ Set knob for warm start (1) to **I**
- ▶ Fit filter cover (3) – make sure not to tilt the screw (2) – insert screw and tighten

18 Adjusting the Carburetor

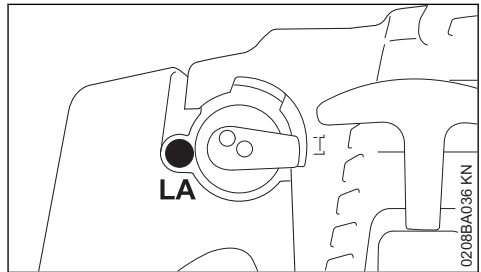

The carburetor of the machine has been adjusted for optimum performance and fuel efficiency in all operating states at the factory.

18.1 Setting the idle speed

Engine stops when idling

- ▶ Turn the idle speed screw (LA) slowly clockwise until the engine runs smoothly.

Cutting attachment turns when idling

- ▶ Turn the idle speed adjusting screw (LA) slowly counterclockwise until the cutting attachment stops turning

! WARNING

If the cutting attachment continues to keep rotating in idle even after adjustment, have the unit checked by a servicing dealer.

19 Spark Plug

- ▶ If the engine is down on power, difficult to start or runs poorly at idle speed, first check the spark plug.
- ▶ Fit a new spark plug after about 100 operating hours – or sooner if the electrodes are badly eroded. Install only suppressed spark plugs of the type approved by STIHL – see "Specifications".

19.1 Removing the spark plug

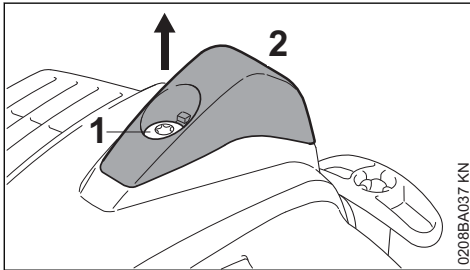

- ▶ Turn screw (1) in cap (2) until cap can be removed
- ▶ Lay down cap

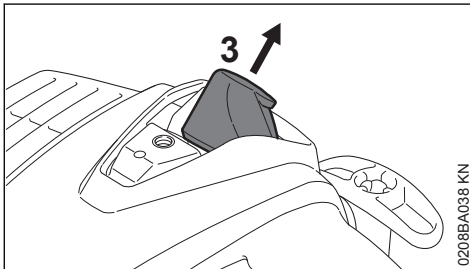

- ▶ Pull off the spark plug boot (3)
- ▶ Unscrew spark plug,

19.2 Checking the Spark Plug

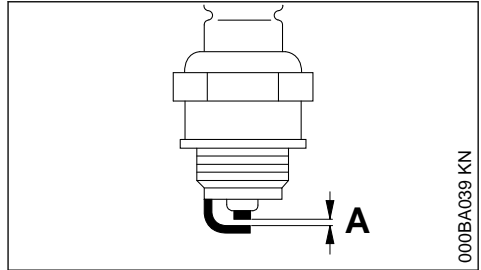

- ▶ Clean dirty spark plug.
- ▶ Check electrode gap (A) and readjust if necessary – see "Specifications".
- ▶ Rectify the problems which have caused fouling of the spark plug.

Possible causes are:

- Too much oil in fuel mix.
- Dirty air filter.
- Unfavorable running conditions.

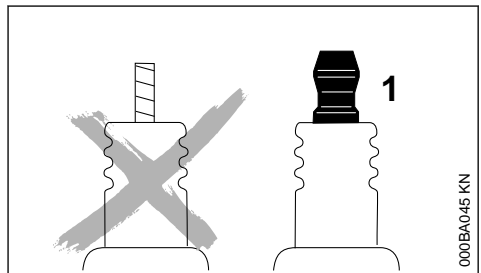

! WARNING

Arcing may occur if the adapter nut (1) is loose or missing. Working in an easily combustible or explosive atmosphere may cause a fire or an explosion. This can result in serious injuries or damage to property.

- ▶ Use resistor type spark plugs with a properly tightened adapter nut.

19.3 Installing the Spark Plug

- ▶ Fit the spark plug and tighten it down firmly.
- ▶ Press the boot firmly onto the spark plug.

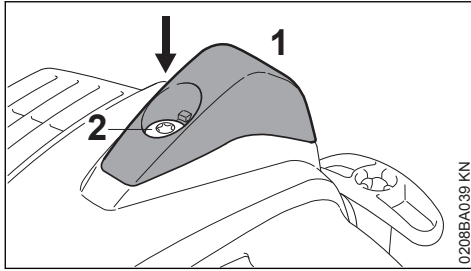

0208BA039 KN

- ▶ Fit the cap (1), insert the screw (2) and tighten it down firmly.

20 Lubricating the Gearbox

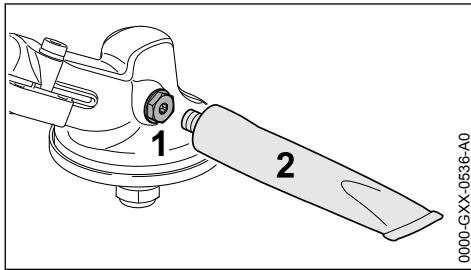

0000-GXX-053E-A0

Check grease level after every 25 hours of operation and re-lubricate if necessary.

- ▶ Remove the screw plug (1).
- ▶ If no grease can be seen on the inside of the screw plug (1): Screw the tube (2) of STIHL gear lubricant (special accessory) into the filler hole.
- ▶ Squeeze no more than 5 g (1/5 oz) grease into the gearbox.

NOTICE

Do not completely fill the gearbox with grease.

- ▶ Unscrew the tube (2).
- ▶ Insert the screw plug (1) and tighten it down firmly.

21 Storing the Machine

If out of use for periods of about 30 days or longer

- ▶ Drain and clean the fuel tank in a well-ventilated area.
- ▶ Dispose of fuel properly in accordance with local environmental requirements.
- ▶ If a manual fuel pump is fitted: Press the manual fuel pump at least 5 times.
- ▶ Start the engine and run it at idling speed until it stops

- ▶ Remove, clean and inspect the cutting attachment. Treat metal cutting attachments with protective oil.
- ▶ Thoroughly clean the machine
- ▶ Cleaning the Air Filter
- ▶ Store the machine in a dry and safe place, out of the reach of children and other unauthorized users

22 Sharpening Metal Cutting Blades

- ▶ Use a sharpening file (special accessory) to sharpen dull cutting attachments. In case of more serious wear or nicks: Resharpener with a grinder or have the work done by a dealer – STIHL recommends a STIHL servicing dealer.
- ▶ Sharpen frequently, take away as little metal as possible – two or three strokes of the file are usually enough.

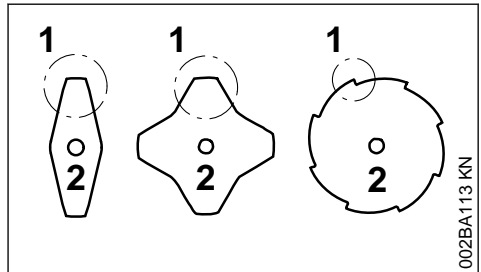

002BA113 KN

- ▶ Resharpener the teeth (1) uniformly – do not alter the contour of the parent blade (2) in any way.

See cutting attachment packaging for additional sharpening instructions. Keep the packaging for future reference.

22.1 Balancing

- ▶ After resharpening about 5 times, check the cutting attachment for out-of-balance on a STIHL balancer (special accessory) or have it checked by a dealer and re-balanced as necessary – STIHL recommends a STIHL servicing dealer.

23 Maintaining the Mowing Head

23.1 Placing power tool on the ground

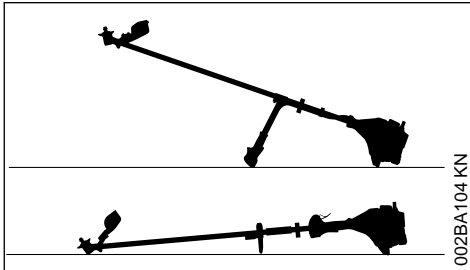

- ▶ Shut off the engine.
- ▶ Lay your power tool on its back so that the cutting attachment mounting face is pointing up.

23.2 Replacing Nylon Line

Always check the mowing head for signs of wear before replacing the nylon line.



WARNING

If there are signs of serious wear, replace the complete mowing head.

The nylon mowing line is referred to as "nylon line" or "line" in the following.

The mowing head is supplied with illustrated instructions for replacing the nylon line. Keep the instructions for the mowing head in a safe place.

- ▶ If necessary, remove the mowing head.

23.3 Adjusting Nylon Line

STIHL SuperCut

Fresh line is advanced automatically if the remaining line is **at least 6 cm (2 1/2 in)** long. The blade on the deflector trims overlong lines to the correct length.

STIHL AutoCut

- ▶ With the engine running, hold the rotating mowing head above the grass surface.
- ▶ Tap it on the ground once – fresh line is advanced and the blade on the deflector trims it to the right length.

Fresh line is advanced every time the mowing head is tapped on the ground. For this reason observe the mowing head's cutting performance during operation. If the mowing head is tapped

on the ground too often, the line limiter blade will unnecessarily cut off unused lengths of nylon line.

Line feed operates only if both lines are still at least **2.5 cm (1 in)** long.

23.4 Replacing Nylon Line

STIHL PolyCut

Precut lengths of nylon line can be fitted to the PolyCut in place of the cutting blades.

STIHL DuroCut, STIHL PolyCut



WARNING

To reduce the risk of injury, always shut off the engine before refilling the mowing head.

- ▶ Fit nylon line in the mowing head as described in the instructions supplied.

23.5 Replacing Cutting Blades

23.5.1 STIHL PolyCut

Always check the mowing head for signs of wear before installing new cutting blades.



WARNING

If there are signs of serious wear, replace the complete mowing head.

The thermoplastic cutting blades are referred to as "blades" in the following.

The mowing head is supplied with illustrated instructions for replacing the blades. Keep the instructions for the mowing head in a safe place.



WARNING

To reduce the risk of injury, always shut off the engine before installing the blades.

- ▶ Remove the mowing head.
- ▶ Replace blades as shown in the illustrated instructions.
- ▶ Mount the mowing head on the machine.

24 Inspection and Maintenance by User

24.1 Throttle Cable

24.1.1 Checking adjustment of throttle cable

Error: Engine speed increases when **only** the throttle trigger is depressed.

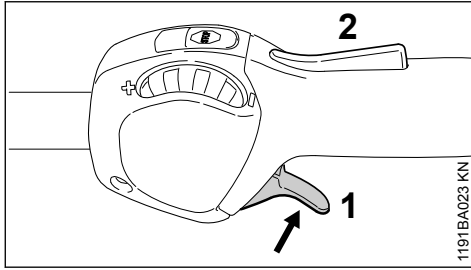

- ▶ Start the engine.
- ▶ Depress the throttle trigger (1) – **do not** press down the throttle trigger lockout (2).

If the engine speed increases or if the cutting attachment rotates, the throttle cable has to be adjusted.

- ▶ Shut off the engine.
- ▶ Have throttle cable adjusted by your dealer. STIHL recommends an authorized STIHL servicing dealer.

25 Inspections and Maintenance by Dealer

25.1 Maintenance work

STIHL recommends that all maintenance and repairs be carried out by STIHL dealers.

25.2 Fuel pickup body in tank

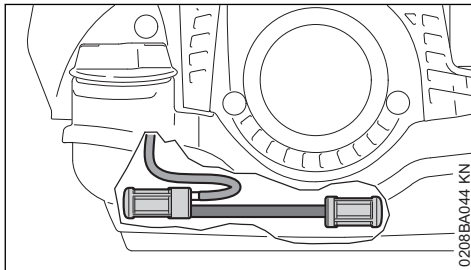

- ▶ Check the pickup bodies in the fuel tank annually and have them replaced when necessary

The pickup bodies should be located in the tank in the areas shown in the figure.

25.3 Antivibration element

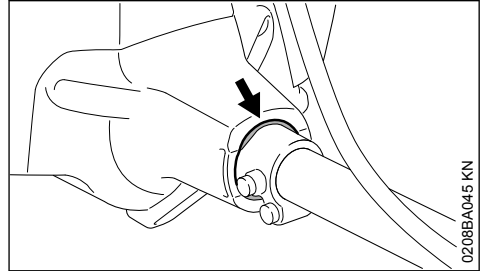

A vibration-absorbing rubber element is installed between the powerhead and the shaft. Have it checked in the event of noticeable wear or constantly increased vibration.

26 Maintenance and Care

The following intervals apply for normal operating conditions. The specified intervals must be shortened accordingly when working for longer than normal or under difficult cutting conditions (extensive dust, etc.).		Before starting work	At the end of work and/or daily	Whenever tank is refilled	Weekly	Monthly	Annually	If faulty	If damaged	As required
Complete machine	Visual inspection (safe condition, leaks)	X		X						
	Clean		X							
	Replace any damaged parts	X								
Control handle	Function test	X		X						
Air filter	Visual inspection					X		X		
	Clean the filter housing									X
	Replace the felt filter ¹⁾								X	X
Fuel tank	Clean				X		X		X	
Manual fuel pump (if present)	check	X								
	Have repaired by a specialist dealer ²⁾								X	
Fuel pickup body in fuel tank	Have checked by dealer ²⁾							X		
	Have replaced by servicing dealer ²⁾					X			X	X
Carburetor	Check idle adjustment, cutting attachment must not turn	X		X						
	Adjust idle speed									X
Spark plug	Set electrode gap							X		
	Replace after every 100 hours of operation									
Intake port for cooling air	Visual inspection		X							
	Clean									X
Cylinder fins	Have cleaned by dealer ²⁾					X				
All accessible screws, nuts and bolts (not adjusting screws)	Tighten									X
Anti-vibration elements	Visual inspection ³⁾	X						X		X
	Have replaced by servicing dealer ²⁾								X	
Cutting attachment	Visual inspection	X		X						
	replace								X	
	Check for secure fit	X		X						

The following intervals apply for normal operating conditions. The specified intervals must be shortened accordingly when working for longer than normal or under difficult cutting conditions (extensive dust, etc.).		Before starting work	At the end of work and/or daily	Whenever tank is refilled	Weekly	Monthly	Annually	If faulty	If damaged	As required
Metal cutting attachment	sharpen	X								X
Gearbox lubrication (with screw plug)	check					X		X		X
	top up									X
Safety information label	replace								X	
¹ Only if there is a noticeable loss of engine power ² STIHL recommends STIHL dealers ³ see chapter "Inspection and Maintenance by Dealer", section "Antivibration Elements"										

27 Minimize Wear and Avoid Damage

Observing the instructions in this manual helps reduce the risk of unnecessary wear and damage to the power tool.

The power tool must be operated, maintained and stored with the due care and attention described in this owner's manual.

The user is responsible for all damage caused by non-observance of the safety precautions, operating and maintenance instructions in this manual. This includes in particular:

- Alterations or modifications to the product not approved by STIHL.
- Using tools or accessories which are neither approved or suitable for the product or are of a poor quality.
- Using the product for purposes for which it was not designed.
- Using the product for sports or competitive events.
- Consequential damage caused by continuing to use the product with defective components.

27.1 Maintenance Work

All the operations described in the "Maintenance Chart" must be performed on a regular basis. If these maintenance operations cannot be performed by the owner, they should be performed by a servicing dealer.

STIHL recommends that you have servicing and repair work carried out exclusively by an author-

ized STIHL servicing dealer. STIHL dealers are regularly given the opportunity to attend training courses and are supplied with the necessary technical information.

If these maintenance operations are not carried out as specified, the user assumes responsibility for any damage that may occur. Among other parts, this includes:

- Damage to the engine due to neglect or deficient maintenance (e.g. air and fuel filters), incorrect carburetor adjustment or inadequate cleaning of cooling air inlets (intake ports, cylinder fins).
- Corrosion and other consequential damage resulting from improper storage.
- Damage to the machine resulting from the use of poor quality replacement parts.

27.2 Parts Subject to Wear and Tear

Some parts of the power tool are subject to normal wear and tear even during regular operation in accordance with instructions and, depending on the type and duration of use, have to be replaced in good time. Among other parts, this includes:

- Cutting attachments (all types)
- Mounting hardware for cutting attachments (rider plate, nut, etc.)
- Deflectors for cutting attachments
- Clutch
- Filters (air, fuel)
- Rewind starter
- Spark plug

– Antivibration elements

28 Main Parts

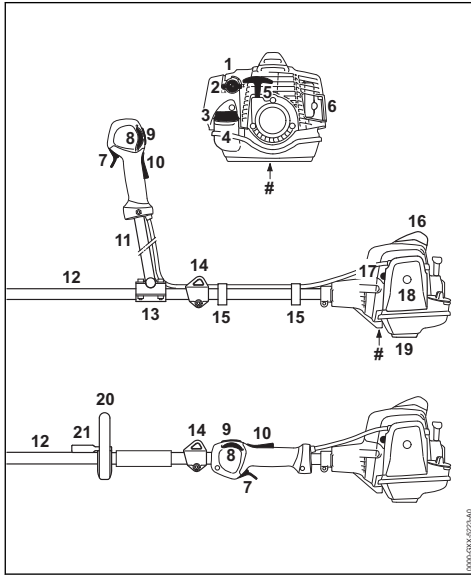

- 1 Choke knob
- 2 Carburetor adjusting screw
- 3 Tank cap
- 4 Fuel tank
- 5 Starter grip
- 6 Muffler
- 7 Throttle trigger
- 8 Set wheel
- 9 Stop switch
- 10 Throttle trigger lockout
- 11 Bike handle (handlebar)
- 12 Drive tube
- 13 Handle support
- 14 Carrying ring
- 15 Throttle cable retainer
- 16 Spark plug boot with cap
- 17 Manual fuel pump
- 18 Air filter cover
- 19 Machine support
- 20 Loop handle
- 21 Barrier bar
- # Serial number

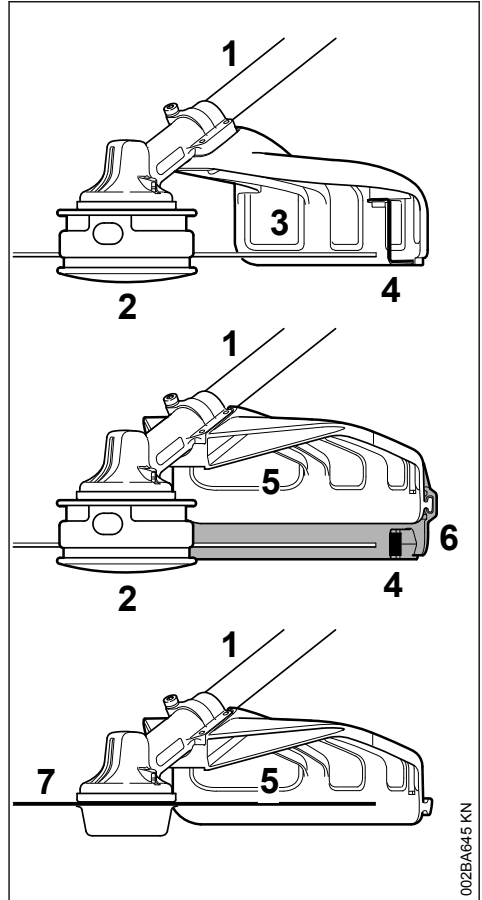

- 1 Drive tube
- 2 Mowing head
- 3 Deflector for mowing heads only
- 4 Blade
- 5 Deflector for all mowing attachments
- 6 Skirt
- 7 Metal mowing attachment

29 Specifications

29.1 Engine

Single cylinder two-stroke engine

Displacement:	24.1 cc
Bore:	35 mm
Stroke:	25 mm
Engine power to ISO 8893:	0.9 kW (1.2 bhp) at 8,000 rpm

Idle speed:	2,800 rpm
Cut-off speed (rated):	9,800 rpm
Max. output shaft speed (cutting attachment):	7,290 rpm

29.2 Ignition System

Electronic magneto ignition

Spark plug (resistor type):	NGK CMR 6 H
Electrode gap:	0.5 mm

29.3 Fuel System

All position rotary valve carburetor with integral fuel pump

Fuel tank capacity:	540 cc (0.54 l)
---------------------	-----------------

29.4 Weight

Dry, without cutting attachment and deflector

FS 94, FS 94 C-E:	4.9 kg
FS 94 RC-E:	4.6 kg

29.5 Overall length

without cutting attachment	1780 mm
----------------------------	---------

29.6 Features

C	Convenience features
R	Loop handle
E	ErgoStart

29.7 Sound and Vibration Levels

For details on compliance with the Vibration Directive 2002/44/EC, visit

www.stihl.com/vib

29.7.1 Sound pressure level L_{peq} in accordance with ISO 22868

FS 94, 94 C-E:	
with mowing head:	93 dB(A)
with metal tool:	93 dB(A)

FS 94 RC-E	
with mowing head:	93 dB(A)
with metal tool:	93 dB(A)

29.7.2 Sound power level L_w in accordance with ISO 22868

FS 94, 94 C-E:	
with mowing head:	108 dB(A)
with metal tool:	107 dB(A)

FS 94 RC-E	
with mowing head:	108 dB(A)
with metal tool:	107 dB(A)

29.7.3 Vibration level $a_{hv,eq}$ in accordance with ISO 22867

FS 94, 94 C-E:

	Handle, left	Handle, right
with mowing head:	4.7 m/s ²	4.0 m/s ²
with metal tool:	4.3 m/s ²	3.5 m/s ²

FS 94 RC-E

	Handle, left	Handle, right
with mowing head:	6.1 m/s ²	6.1 m/s ²
with metal tool:	5.5 m/s ²	5.5 m/s ²

29.7.4 Interchangeable attachments

The noise and vibration data of the approved attachments are listed in the instructions supplied with each attachment.

The K-factor in accordance with Directive 2006/42/EC is 2.0 dB(A) for the sound pressure level and sound power level; the K-factor in accordance with Directive 2006/42/EC is 2.0 m/s² for the vibration level.

29.8 REACH

REACH is an EC regulation and stands for the Registration, Evaluation, Authorization and Restriction of Chemical substances.

For information on compliance with the REACH regulation (EC) No. 1907/2006 see

www.stihl.com/reach

29.9 Exhaust Emissions

The CO₂ value measured in the EU type approval procedure is specified at

www.stihl.com/co2

in the product-specific technical data.

The measured CO₂ value was determined on a representative engine in accordance with a standardized test procedure under laboratory conditions and does not represent either an explicit or implied guarantee of the performance of a specific engine.

The applicable exhaust emission requirements are fulfilled by the intended usage and maintenance described in this User Manual. The operating license shall be void if the engine is modified in any way.

30 Maintenance and Repairs

Users of this machine may only carry out the maintenance and service work described in this user manual. All other repairs must be carried out by a servicing dealer.

STIHL recommends that you have servicing and repair work carried out exclusively by an authorized STIHL servicing dealer. STIHL dealers are regularly given the opportunity to attend training courses and are supplied with the necessary technical information.

When repairing the machine, only use replacement parts which have been approved by STIHL for this power tool or are technically identical. Only use high-quality replacement parts in order to avoid the risk of accidents and damage to the machine.

STIHL recommends the use of original STIHL replacement parts.

Original STIHL parts can be identified by the STIHL part number, the **STIHL** logo and the STIHL parts symbol  (the symbol may appear alone on small parts).

31 Disposal

Contact the local authorities or your STIHL servicing dealer for information on disposal.

Improper disposal can be harmful to health and pollute the environment.

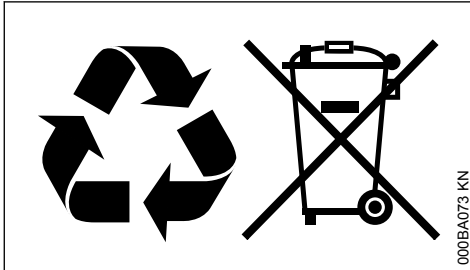

- ▶ Take STIHL products including packaging to a suitable collection point for recycling in accordance with local regulations.
- ▶ Do not dispose with domestic waste.

32 EC Declaration of Conformity

ANDREAS STIHL AG & Co. KG
Badstr. 115
D-71336 Waiblingen
Germany

declare under our sole responsibility that

Designation:	Brushcutter
Make:	STIHL
Series:	FS 94 FS 94 RC-E

	FS 94 RC-E
Serial identification number:	4149
Displacement	24.1 cm ³

conforms to the relevant provisions of Directives 2011/65/EU, 2006/42/EC, 2014/30/EU and 2000/14/EC and has been developed and manufactured in compliance with the following standards in the versions valid on the date of production:

EN ISO 11806-1, EN 55012, EN 61000-6-1

The measured and the guaranteed sound power level have been determined in accordance with Directive 2000/14/EC, Annex V, and standard ISO 10884.

Measured sound power level

108 dB(A)

Guaranteed sound power level

110 dB(A)

Technical documents deposited at:

ANDREAS STIHL AG & Co. KG
Produktzulassung

The year of manufacture and serial number are applied to the product.

Waiblingen, 15.07.2021

ANDREAS STIHL AG & Co. KG

pp



Dr. Jürgen Hoffmann

Director Product Certification & Regulatory Affairs

CE

33 UKCA Declaration of Conformity

ANDREAS STIHL AG & Co. KG
Badstr. 115
D-71336 Waiblingen

Germany

declare under our sole responsibility that

Designation:	Brushcutter
Make:	STIHL

Series: FS 94
FS 94 C-E
FS 94 RC-E
Serial identification number: 4149
Displacement 24.1cm³

conforms to the relevant provisions of UK regulations The Restriction of the Use of Certain Hazardous Substances in Electrical and Electronic Equipment Regulations 2012, Supply of Machinery (Safety) Regulations 2008, Electromagnetic Compatibility Regulations 2016 and Noise Emission in the Environment by Equipment for use Outdoors Regulations 2001 and has been manufactured in compliance with the following standards in the versions valid on the date of production:

EN ISO 11806-1, EN 55012, EN 61000-6-1

The measured and guaranteed sound power levels were determined in accordance with the UK regulation Noise Emission in the Environment by Equipment for use Outdoors Regulations 2001, Schedule 8, using the ISO 10884 standard.

Measured sound power level

108 dB(A)

Guaranteed sound power level

110 dB(A)

Technical documents deposited at:

ANDREAS STIHL AG & Co. KG

The year of manufacture and serial number are indicated on the product.

Done at Waiblingen, 15.07.2021

ANDREAS STIHL AG & Co. KG

pp



Dr. Jürgen Hoffmann

Director Product Certification & Regulatory
Affairs



www.stihl.com



0458-593-0121-C



0458-593-0121-C